

STRUCTALL BUILDING SYSTEMS PANEL SPAN TABLES:

3" x 0.030 x 1 - LB EPS PANELS (OPEN STRUCTURES-EXPOSURE B)					
WIND SPEED	NET ULTIMATE LOAD (PSF) ¹	MAX. ALLOWABLE SPAN (FT)			
		L/60 & L/80	L/120	L/180	L/240
110	20.4	17.66	17.21	15.36	14.00
120	24.3	17.14	16.39	14.53	13.17
130	28.5	16.58	15.63	13.78	12.41
140	33.1	16.00	14.93	13.07	11.71
150	38.0	15.40	14.28	12.42	11.05
160	43.2	14.79	13.67	11.81	10.44
180	54.7	13.52	12.56	10.69	9.33

3" x 0.030 x 1 - LB EPS PANELS (OPEN STRUCTURES-EXPOSURE C)					
WIND SPEED	NET ULTIMATE LOAD (PSF) ¹	MAX. ALLOWABLE SPAN (FT)			
		L/60 & L/80	L/120	L/180	L/240
110	30.4	16.34	15.33	13.47	12.11
120	36.2	15.62	14.51	12.64	11.28
130	42.5	14.87	13.75	11.88	10.52
140	49.3	14.10	13.05	11.18	9.81
150	56.6	13.32	12.40	10.52	9.16
160	64.4	12.53	11.79	9.91	8.55
180	81.5	10.97	10.67	8.79	7.43

¹ MULTIPLY ULTIMATE LOADS BY 0.6 FOR ALLOWABLE LOADS

3" x 0.030 x 1 - LB EPS PANELS (ENCLOSED STRUCTURES-EXPOSURE B)					
WIND SPEED	NET ULTIMATE LOAD (PSF) ¹	MAX. ALLOWABLE SPAN (FT)			
		L/60 & L/80	L/120	L/180	L/240
110	16.3	18.64	18.27	16.43	15.06
120	19.4	17.80	17.45	15.60	14.24
130	22.8	17.34	16.69	14.84	13.47
140	26.4	16.86	16.00	14.14	12.78
150	30.4	16.34	15.33	13.47	12.11
160	34.5	15.82	14.73	12.87	11.51
180	43.7	14.73	13.62	11.75	10.39

3" x 0.030 x 1 - LB EPS PANELS (ENCLOSED STRUCTURES-EXPOSURE C)					
WIND SPEED	NET ULTIMATE LOAD (PSF) ¹	MAX. ALLOWABLE SPAN (FT)			
		L/60 & L/80	L/120	L/180	L/240
110	24.3	17.13	16.39	14.53	13.17
120	29.0	16.52	15.55	13.69	12.33
130	34.0	15.89	14.80	12.94	11.58
140	39.4	15.23	14.11	12.24	10.88
150	45.3	14.55	13.45	11.58	10.22
160	51.5	13.86	12.84	10.97	9.61
180	65.2	12.45	11.73	9.85	8.49

¹ MULTIPLY ULTIMATE LOADS BY 0.6 FOR ALLOWABLE LOADS

3" x 0.030 x 1 - LB EPS PANELS (ATTACHED STRUCTURE-PARTIALLY OPEN) (EXPOSURE B)					
WIND SPEED	NET ULTIMATE LOAD (PSF) ¹	MAX. ALLOWABLE SPAN (FT)			
		L/60 & L/80	L/120	L/180	L/240
110	21.7	17.49	16.92	15.07	13.71
120	25.8	16.93	16.10	14.25	12.88
130	30.3	16.35	15.35	13.49	12.12
140	35.1	15.75	14.65	12.79	11.42
150	40.3	15.12	14.00	12.13	10.77
160	45.9	14.48	13.39	11.52	10.16
180	58.1	13.17	12.27	10.40	9.04

3" x 0.030 x 1 - LB EPS PANELS (ATTACHED STRUCTURE-PARTIALLY OPEN) (EXPOSURE C)					
WIND SPEED	NET ULTIMATE LOAD (PSF) ¹	MAX. ALLOWABLE SPAN (FT)			
		L/60 & L/80	L/120	L/180	L/240
110	32.3	16.10	15.04	13.18	11.82
120	38.5	15.34	14.21	12.35	10.99
130	45.2	14.56	13.46	11.59	10.23
140	52.4	13.76	12.76	10.89	9.53
150	60.1	12.96	12.11	10.24	8.88
160	68.4	12.15	11.50	9.63	8.26
180	86.6	10.54	10.39	8.51	7.14

¹ MULTIPLY ULTIMATE LOADS BY 0.6 FOR ALLOWABLE LOADS

PRODUCT APPROVAL DETAILS:

- BLDG CODE: 7th EDITION FLORIDA BUILDING CODE (2020 FBC)
- LIMITS OF USE: FOR PATIO USE ONLY (RISK CATEGORY I).
 - CARPORTS
 - PATIO COVERS
 - SUNROOMS
 - SCREEN ENCLOSURES
 - CANOPIES
 - OTHER SIMILAR MINOR STRUCTURES

Note

- All product performance specifications and construction requirements shall be engineered by a licensed design professional in accordance with the Aluminum Design Manual, *Specifications & Guidelines for Aluminum Structures, Washington, DC*, for wind resistance in conformance to FBC Chapter 16 for Components and Cladding Loads, ASCE 7-16 Chapter 30 for Components and Cladding. Effective area for wind load calculations based on 50 sq. feet (absolute value of controlling design wind pressure is shown on span tables).
- Span schedule show maximum roof panel spans between two sided clear supports as shown.
- Wind load design pressures in span tables are calculated in accordance to ASCE 7-16, Components & Cladding loads as required in FBC Table 2002.4. Mean roof height of structure shall not exceed 15 feet above grade. Span tables for open and partially open structures based on 7.5° max. roof slope and used the avg. of free flow and obstructed flow net pressure coefficients. Span tables for enclosed structures based on 27° max. roof slope.
- Each roof panel shall be connected per design professional's instructions, but may use min. per details shown on this dwg. at each support (or other approved connection by design professional) w/ min. 0.040" thick, 6063-T6 aluminum base metal. Edge panels shall be supported on min. three sides or per design professional's instructions. Details 1 & 2 are reflective of the boundary conditions utilized in the testing of panels as referenced in the test reports.
- Composite panels shall be constructed using type 3105-H154 aluminum facings, 1 or 2 PCF ASTM C-578 Imperial Foam & Insulation Manufacturing brand EPS adhered to aluminum facings with Morad M640 Series adhesive (by Rohm and Haas Company). Fabrication to be by Structall panel products only in accordance with approved fabrication methods.
- Structall roof panels maintain a UL 1715 (int) class 'B' (ext) rating and are NER-501 approved.
- This specification has been designed and shall be fabricated in accordance with the requirements of the Florida Building Code 7th Edition (2020 FBC), composite panels comply with Chapter 7 Section 720, Chapter 8 Section 803, Class A interior finish, and Chapter 26 Section 2603. All local building code amendments shall be adhered to as required.
- The designer shall determine by accepted engineering practice the design loads for site specific load conditions (including load combinations) using the data from the loads tables and spans in this approval.
- Deflection limits and allowable spans have been listed to meet FBC including the HVHZ. In HVHZ, this product shall be used in structures meeting the requirements of Section 1626.1, unless impact resistance in accordance to the HVHZ requirements are met.
- Safety factor of 2.0 has been use to develop allowable loads and spans from testing in accordance to the Guidelines for Aluminum Structures Part 1 and conforms to the FBC Chapter 16 and 20.
- Testing has been conducted in accordance to ASTM E72: Strength Test of Panels for Building Construction.
- Linear interpolation shall be allowed for figures within the tables shown.
- Panels with fan beams shall be considered equivalent to similar panels without fan beams. Design professionals may include the strength of the fan beam to exceed shown figures as part of site-specific engineering.
- Reference test reports conducted by PRI-Construction Materials Technologies LLC., 6412 Badger Drive, Tampa, FL 33610, (813) 621-5777 can be found in the product evaluation report (FL#21443).

DO KIM
& ASSOCIATES, LLC

**CONSULTING
STRUCTURAL
ENGINEERS**

PO BOX 10039
Tampa, FL 33679
Tel: (813) 857-9955

Rev./Date	Description
△ 10/15/2020	ISSUED FOR PRODUCT APPROVAL
△	
△	
△	
△	

Structall Building Systems
 350 Burbank Road
 Oldsmar, FL 34677
 3"x0.030"x1 LB EPS FOAM CORE
 COMPOSITE ALUMINUM SKIN PANELS
 FLORIDA STATEWIDE PRODUCT APPROVAL

DRAWN BY:	DYK
CHECKED BY:	DYK
SCALE:	AS SHOWN
DATE:	10/19/16

DO YEON KIM, P.E.
FLA. REG. NUMBER 49497



This form has been digitally signed and sealed by Do Y. Kim on the date adjacent to the seal. Printed copies of this document are not considered signed and sealed and the signature must be verified on any electronic copies.

Drawing No. - 202003

SHEET 1 OF 2

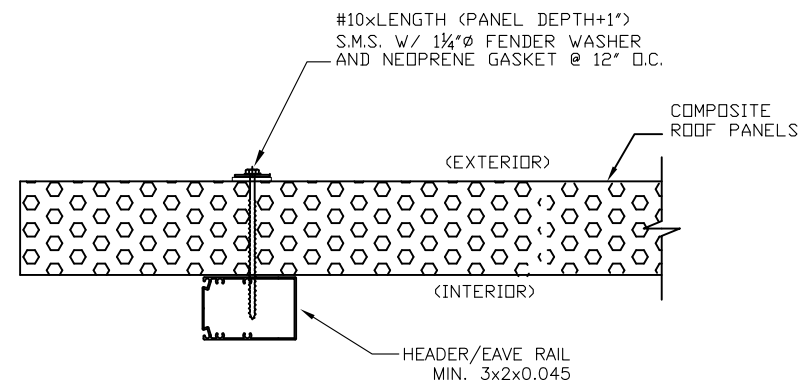

DETAIL 2

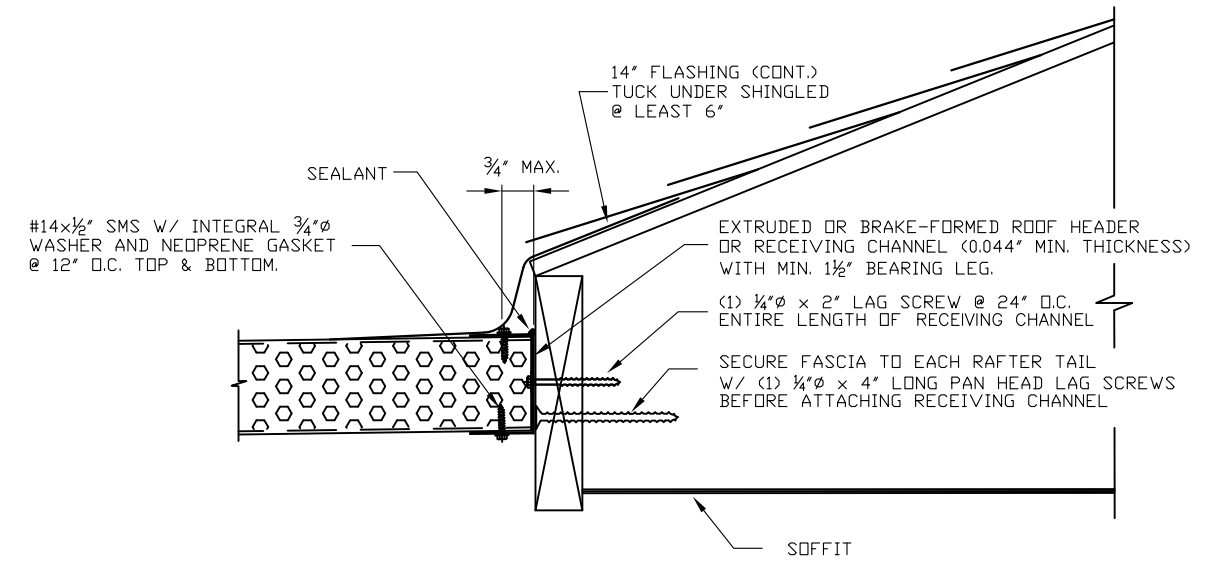

(OR)

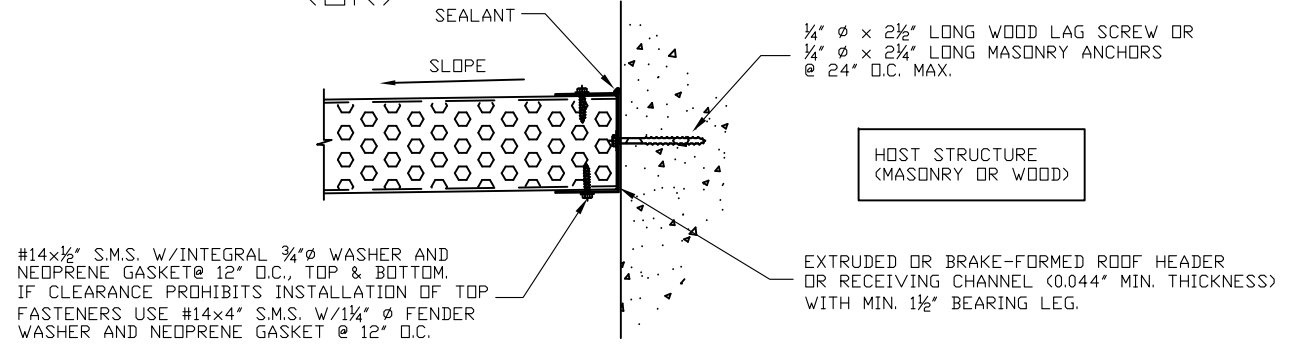

DETAIL 1

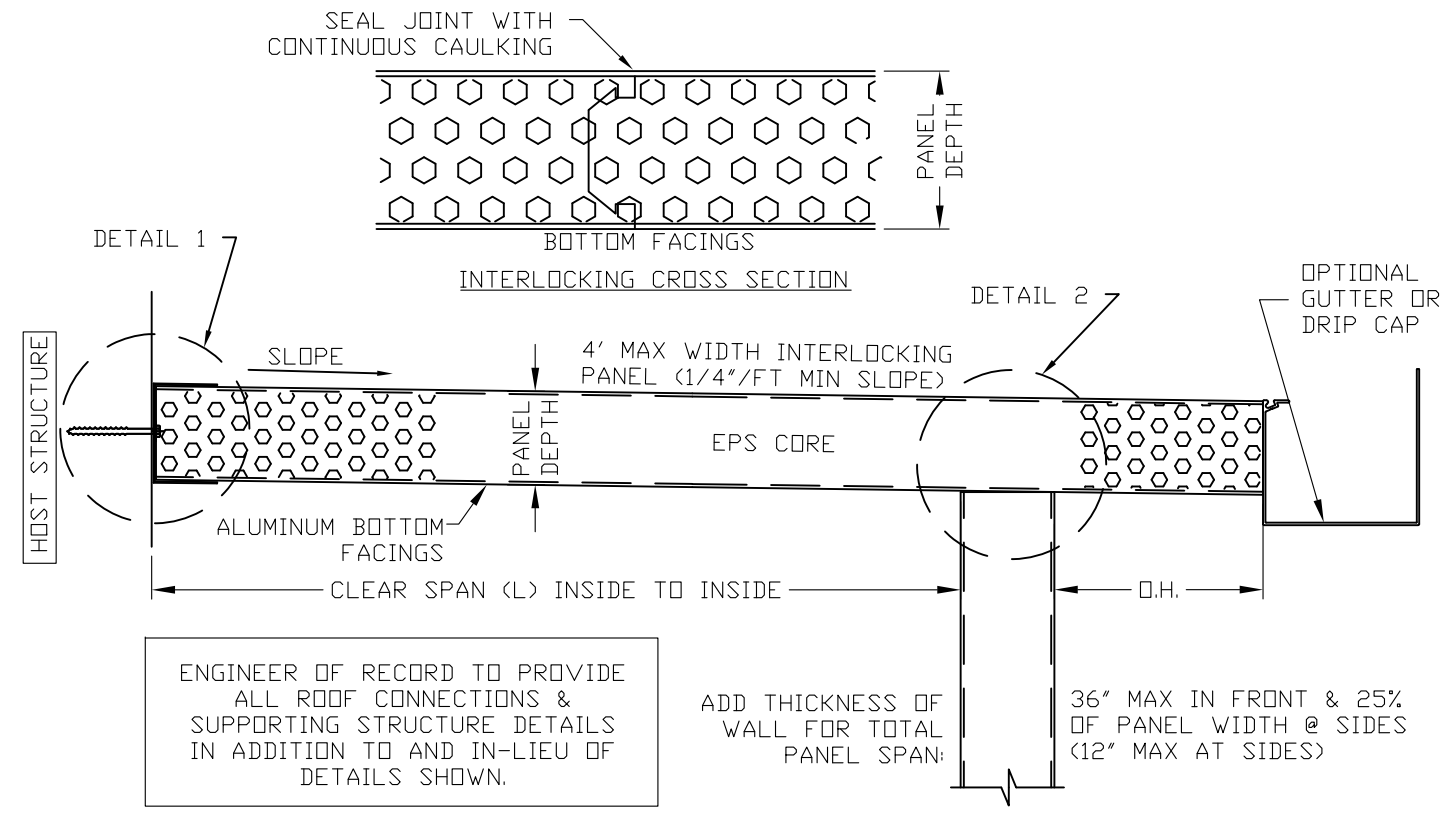

ENGINEER OF RECORD TO PROVIDE ALL ROOF CONNECTIONS & SUPPORTING STRUCTURE DETAILS IN ADDITION TO AND IN-LIEU OF DETAILS SHOWN.

ADD THICKNESS OF WALL FOR TOTAL PANEL SPAN:

36" MAX IN FRONT & 25% OF PANEL WIDTH @ SIDES (12" MAX AT SIDES)

EPS ROOF PANEL/ SPAN DESCRIPTION

DO KIM & ASSOCIATES, LLC

CONSULTING STRUCTURAL ENGINEERS

PO BOX 10039
Tampa, FL 33679
Tel: (813) 857-9955

Rev./Date	Description
10/15/2020	ISSUED FOR PRODUCT APPROVAL

Structall Building Systems
350 Burbank Road
Oldsmar, FL 34677

3"x0.030"x1 LB EPS FOAM CORE
COMPOSITE ALUMINUM SKIN PANELS
FLORIDA STATEWIDE PRODUCT APPROVAL

DRAWN BY:	DYK
CHECKED BY:	DYK
SCALE:	AS SHOWN
DATE:	10/19/16

DO YEON KIM, P.E.
FLA. REG. NUMBER 49497

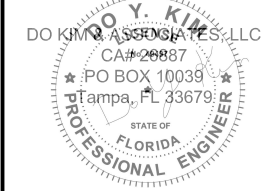

This item has been digitally signed and sealed by Do Y. Kim on the date adjacent to the seal. Printed copies of this document are not considered signed and sealed and the signature must be verified on any electronic copies.

Drawing No. - 202003

SHEET 2 OF 2